

MN1382S

CMOS IC for Voltage Detection

■ Overview

The MN1382S are elements that monitor the power supply voltage supplied to microcomputers and other LSI systems and issue reset signals for initializing the system after the power is first applied or for preventing runaway operation when the supply voltage fluctuates.

This is a CMOS output, choose the ideal element for your application from the series' wide selection of detection ranks (16 ranks 2.0 V to 4.7 V).

There is other output type, N-channel open drain output (MN13821S) and inverted CMOS output (MN13822S).

■ Features

- Three-pin element requiring no adjustment
- Wide selection of detection ranks (16 ranks 2.0 V to 4.7 V)
- Highly precise detection voltage
- Detection voltage with hysteresis characteristic
 $\Delta V_D = 50 \text{ mV}$ for ranks C to K
 $\Delta V_D = 100 \text{ mV}$ for ranks L to T
- Low current consumption: $I_{DD} = 1 \mu\text{A}$ (typ.) for $V_{DD} = 5 \text{ V}$
- Low fluctuation in detection voltage with temperature (1 mV/°C (typ.))

■ Applications

- Battery checkers
- Power outage detectors
- Level discriminators
- Memory backup systems
- Microcomputer reset circuits
- Reset circuits for other electronic circuits

■ Block Diagram

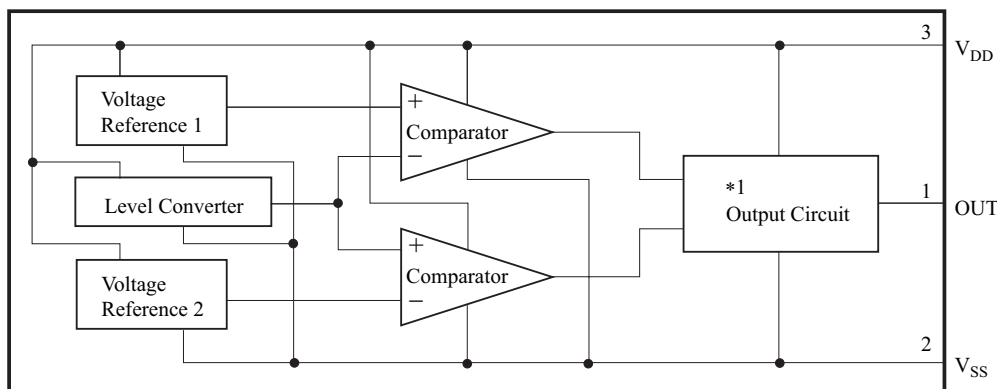

Note) *1: Circuits vary slightly depending on the output type (CMOS output, N-channel open drain output, or inverted CMOSoutput)

■ Package

- Code
MINI-3DC
- Pin name
 1: Out Reset signal output pin
 2: V_{SS} Ground pin
 3: V_{DD} Power supply pin

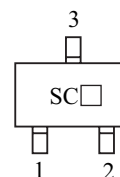

Note) Rank symbol will be marked on the package in the □ area.

■ Detection Ranks (on Voltage)

Rank	Detection Voltage for Drop in Power Supply Voltage V_{DL}		Unit	Detection Voltage Hysteresis Width ΔV_D		Unit
	Min	Max		Min	max	
C	2.0	2.2	V	50	300	mV
D	2.1	2.3				
E	2.2	2.4				
F	2.3	2.5				
G	2.4	2.6				
H	2.5	2.7				
J	2.6	2.9				
K	2.8	3.1				
L	3.0	3.3		100		
M	3.2	3.5				
N	3.4	3.7				
P	3.6	3.9				
Q	3.8	4.1				
R	4.0	4.3				
S	4.2	4.5				
T	4.4	4.7				

■ Absolute Maximum Ratings $V_{SS} = 0\text{ V}$, $T_a = 25^\circ\text{C}$

Parameter	Symbol	Rating	Unit
Power supply voltage	V_{DD}	7.0	V
Output voltage	V_O	-0.3 to $V_{DD} + 0.3$	V
Operating ambient temperature	T_{opr}	-20 to +70	$^\circ\text{C}$
Storage temperature	T_{stg}	-55 to +125	$^\circ\text{C}$

■ Recommended Operating Conditions $V_{SS} = 0\text{ V}$, $T_a = 25^\circ\text{C}$

Parameter	Symbol	Conditions	Min	Typ	Max	Unit
Power supply voltage	V_{DD}	See Figures 1 and 4	1.5		6.0	V

■ Application Circuit Example



Note) Connect resistors, capacitors, and the like only to the output pin on the MN1382S element.

Note that connect-ing them to the power source pins changes V_{DH} , V_{DL} , and ΔV_D . Select the values of R and C to match the application.

■ Electrical Characteristics

• DC Characteristics $V_{SS} = 0\text{ V}$, $T_a = -20^\circ\text{C}$ to $+70^\circ\text{C}$

Parameter	Symbol	Conditions	Min	Typ	Max	Unit
Power supply current	I_{DD}	$V_{DD} = 5\text{ V}^*$, Load resistor $10\text{ k}\Omega$		1	5	μA
Detection voltage for drop in power supply voltage	V_{DL}	$T_a = 25^\circ\text{C}$ See Figures 1 and 4	For particulars, see the detection voltage rank table.			V
Detection voltage hysteresis width	ΔVD					mV
High level output voltage	V_{OH}	$I_{OH} = -40\ \mu\text{A}$	$0.8 V_{DD}$		V_{DD}	V
Low level output voltage	V_{OL}	$V_{DD} = 1.8\text{ V}$, $I_{OH} = 0.7\text{ mA}$	V_{SS}		0.4	V

Note) *: This includes the output pin's leakage current.

• AC Characteristics $V_{SS} = 0\text{ V}$, $T_a = 25^\circ\text{C}$

Parameter	Symbol	Conditions	Rank	Allowable Value (typ)	Unit
Reset release time	t_{OH}	See Figures 2 and 3	C	3.0	μs
			D		
			E		
			F		
			G		
			H		
			J		
			K	4.0	
			L		
			M		
			N		
			P		
			Q		
			R		
S					
T					
Reset time	t_{OL}	See Figures 2 and 3	C	250.0	μs
			D		
			E		
			F		
			G	115.0	
			H		
			J		
			K		
			L	70.0	
			M	15.0	
			N		
			P		
			Q		
			R		
S					
T					

■ Reference Data

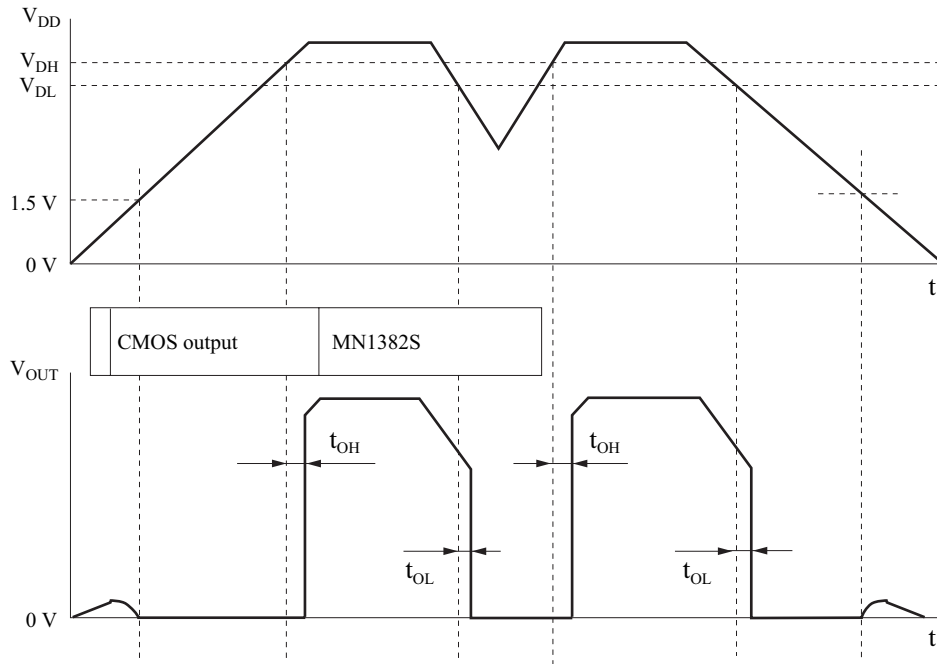

Figure 1. Description of Operation

Note) 1. Output cannot be specified for power supply voltages under 1.5 V because operation is not guaranteed for that range.

2. V_{DL} : Detection voltage for drop in power supply voltage

V_{DH} : Detection voltage for rise in power supply voltage

t_{OL} : Time lag between the time that the power supply voltage reaches the detection voltage (V_{DL} or V_{DH}) and the time that the output pin (OUT) goes to Low level.

t_{OH} : Time lag between the time that the power supply voltage reaches the detection voltage (V_{DL} or V_{DH}) and the time that the output pin (OUT) goes to High level.

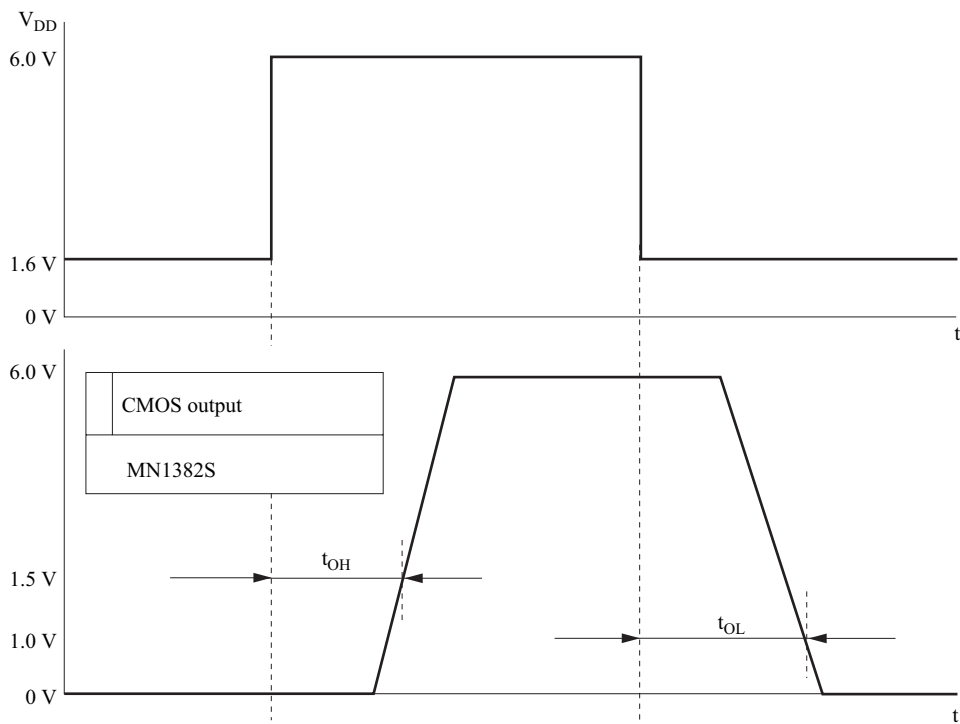

Figure 2. Description chart of Measuring the Output Characteristics

■ Reference Data (Continued)

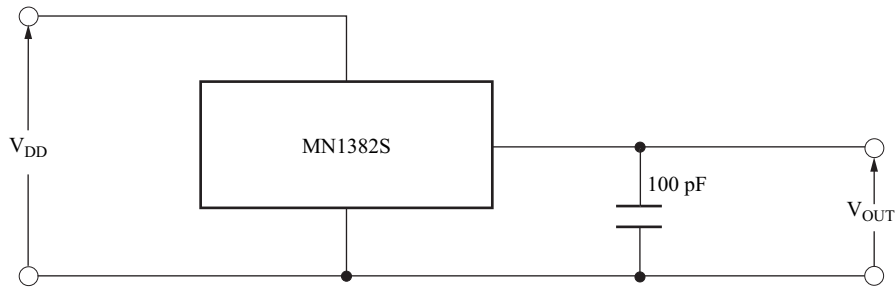

Figure 3. Circuit for Measuring the Output Characteristics

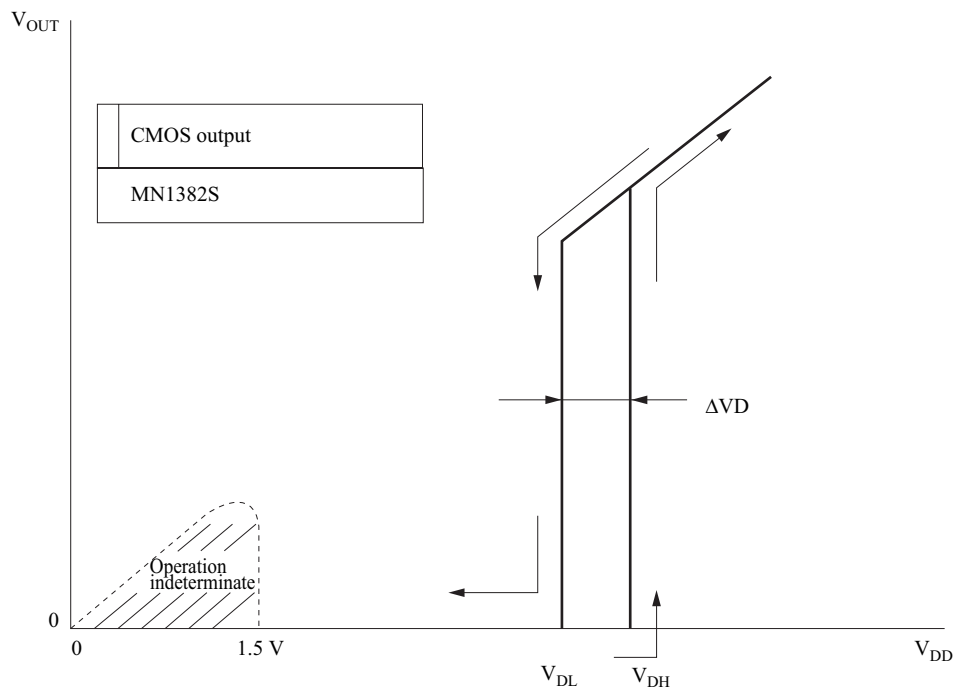

Figure 4. Description chart for Measuring the I/O Characteristics

- Note) 1. Output cannot be specified for power supply voltages under 1.5 V because operation is not guaranteed for that range.
 2. V_{DL} : Detection voltage for drop in power supply voltage
 V_{DH} : Detection voltage for rise in power supply voltage

■ Reference Characteristics

The following characteristics curves represent results from a specific sample therefore they do not guarantee the characteristics for the final product.

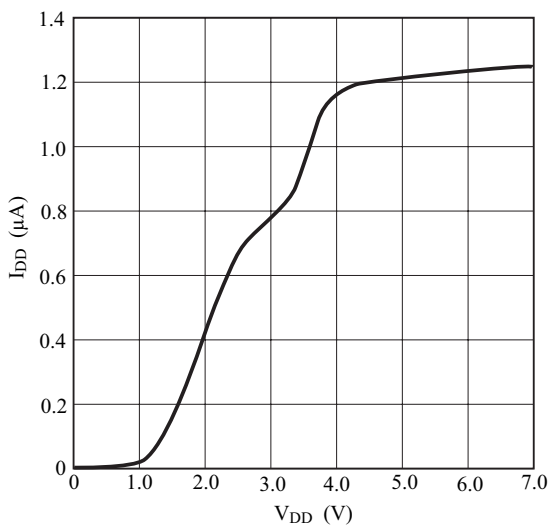

Figure 5-a I_{DD} — V_{DD} Characteristic (Rank Q)

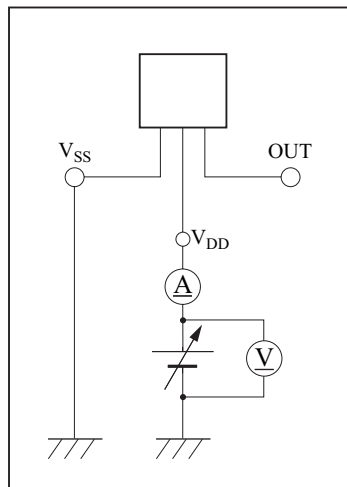

Figure 5-b Measurement Circuit

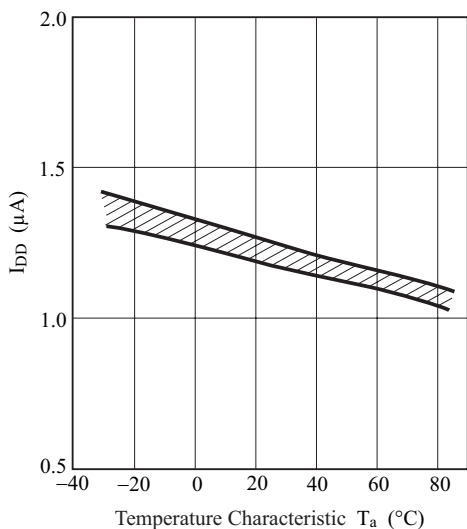

Figure 6-a I_{DD} — Temperature Characteristic (Rank Q)

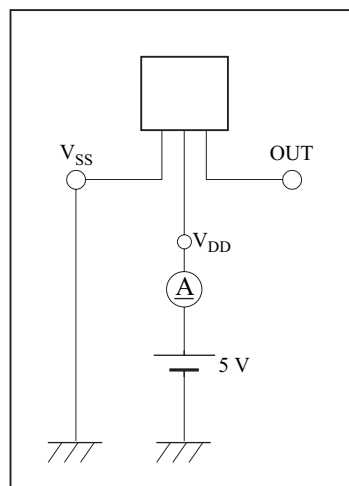

Figure 6-b Measurement Circuit

■ Reference Characteristics (Continued)

The following characteristics curves represent results from a specific sample therefore they do not guarantee the characteristics for the final product.

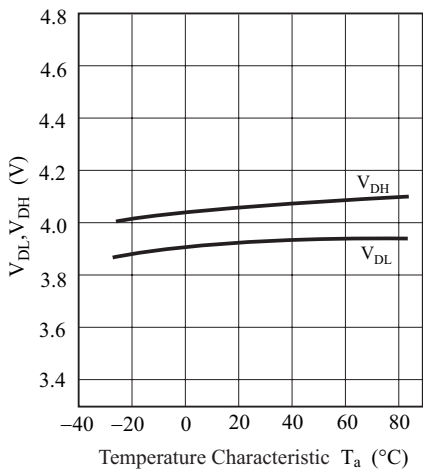

Figure 7-a V_{DL} — V_{DH} Temperature Characteristic (Rank Q)

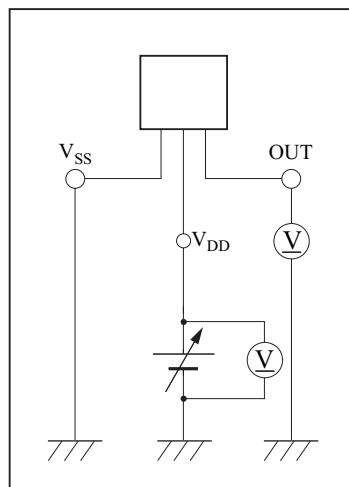

Figure 7-b Measurement Circuit

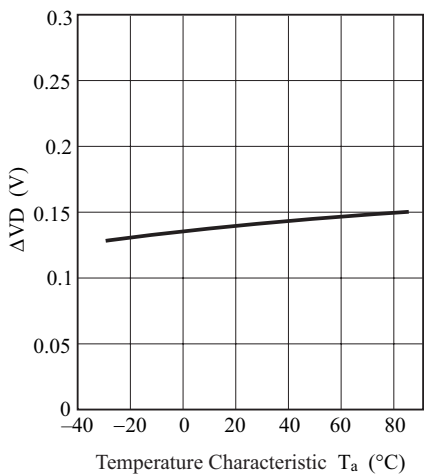

Figure 8-a ΔV_D Temperature Characteristic (Rank Q)

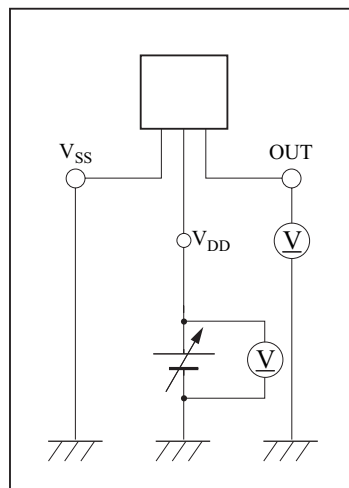

Figure 8-b Measurement Circuit

■ Reference Characteristics (Continued)

The following characteristics curves represent results from a specific sample therefore they do not guarantee the characteristics for the final product.

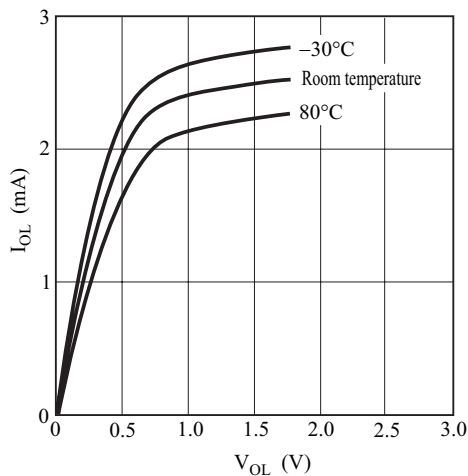

Figure 9-a I_{OL} — V_{OL} Characteristic

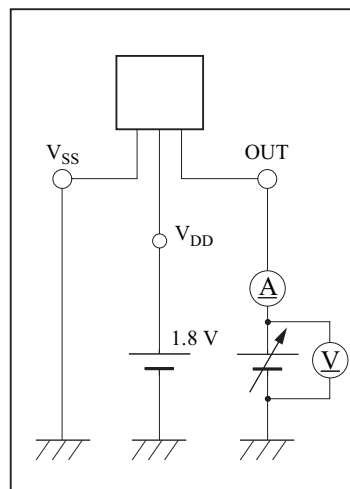

Figure 9-b Measurement Circuit

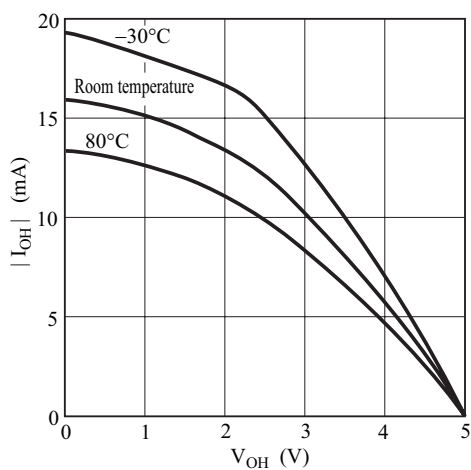

Figure 10-a |I_{OH}| — V_{OH} Characteristic

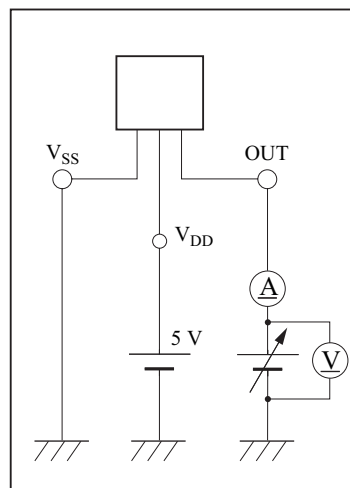

Figure 10-b Measurement Circuit

■ Reference Characteristics (Continued)

The following characteristics curves represent results from a specific sample therefore they do not guarantee the characteristics for the final product.

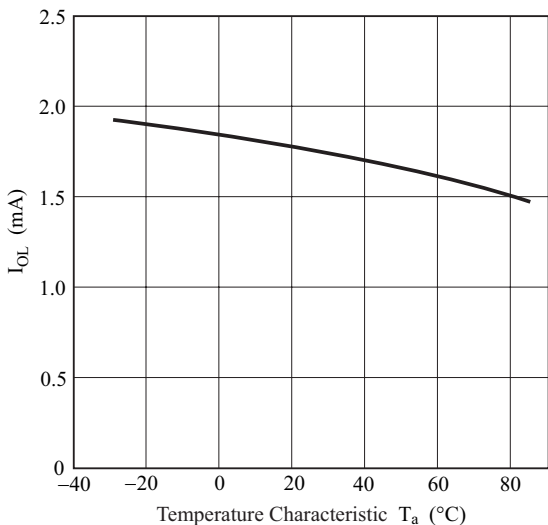

Figure 11-a I_{OL} — Temperature Characteristic

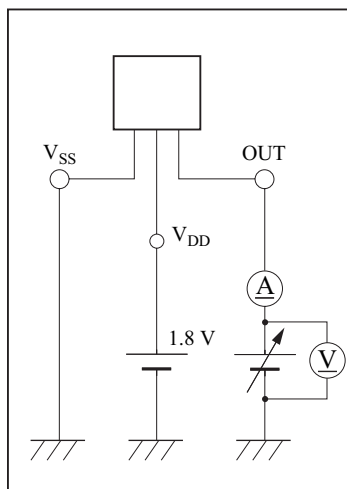

Figure 11-b Measurement Circuit

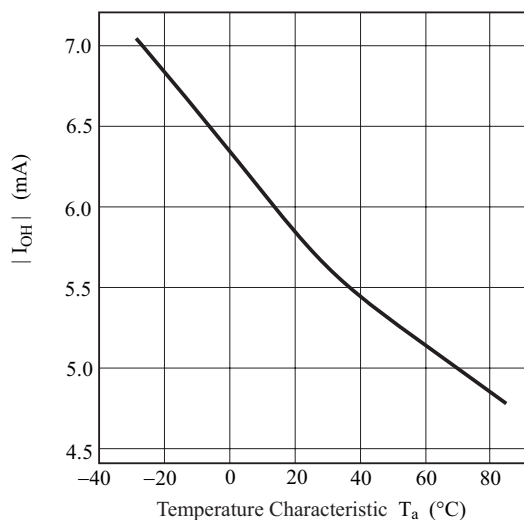

Figure 12-a I_{OH} — Temperature Characteristic

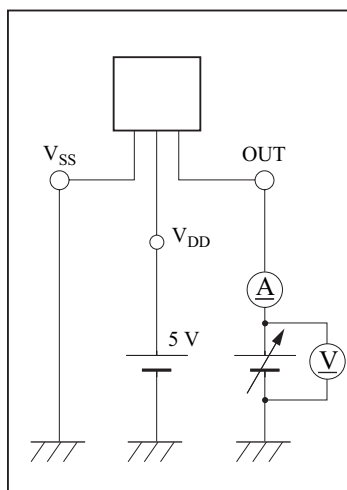
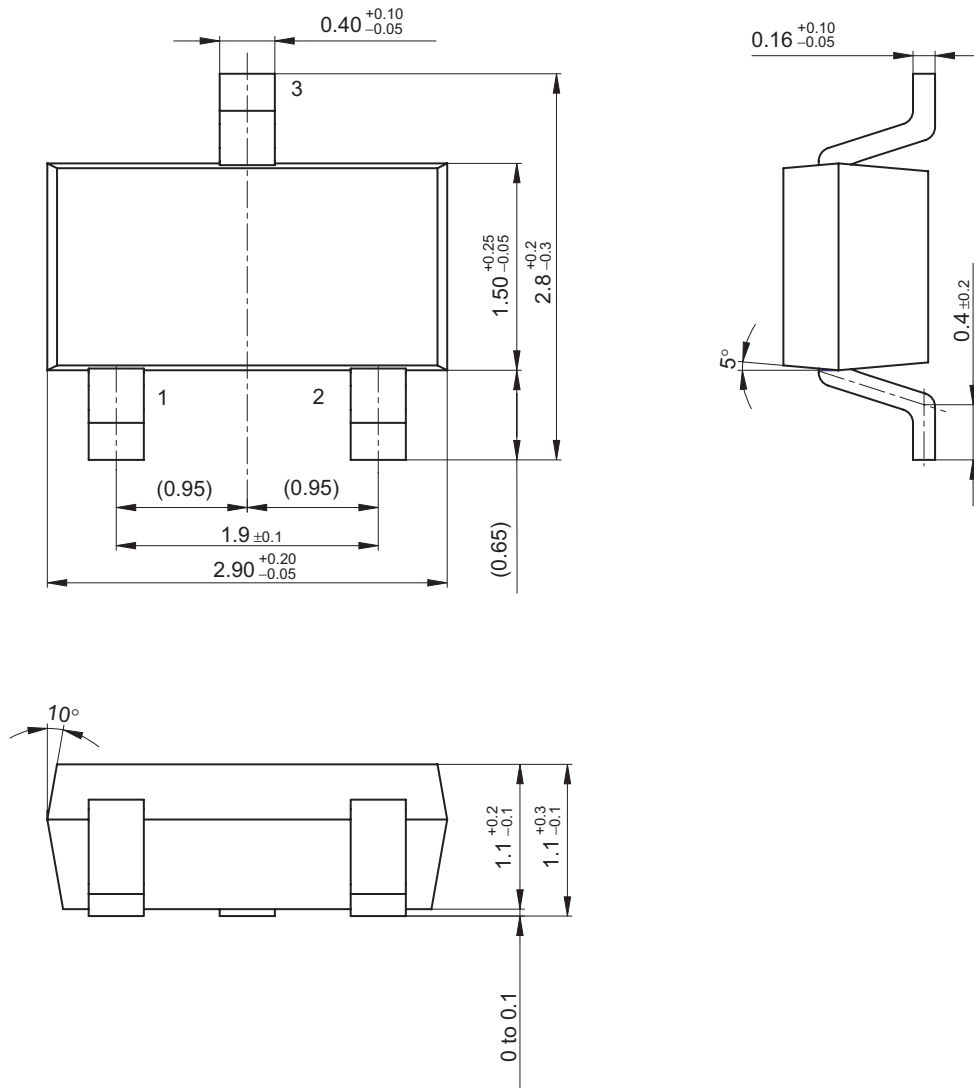

Figure 12-b Measurement Circuit

MINI-3DC



Request for your special attention and precautions in using the technical information and semiconductors described in this book

- (1) If any of the products or technical information described in this book is to be exported or provided to non-residents, the laws and regulations of the exporting country, especially, those with regard to security export control, must be observed.
- (2) The technical information described in this book is intended only to show the main characteristics and application circuit examples of the products, and no license is granted under any intellectual property right or other right owned by our company or any other company. Therefore, no responsibility is assumed by our company as to the infringement upon any such right owned by any other company which may arise as a result of the use of technical information described in this book.
- (3) The products described in this book are intended to be used for standard applications or general electronic equipment (such as office equipment, communications equipment, measuring instruments and household appliances).
Consult our sales staff in advance for information on the following applications:
 - Special applications (such as for airplanes, aerospace, automobiles, traffic control equipment, combustion equipment, life support systems and safety devices) in which exceptional quality and reliability are required, or if the failure or malfunction of the products may directly jeopardize life or harm the human body.
 - Any applications other than the standard applications intended.
- (4) The products and product specifications described in this book are subject to change without notice for modification and/or improvement. At the final stage of your design, purchasing, or use of the products, therefore, ask for the most up-to-date Product Standards in advance to make sure that the latest specifications satisfy your requirements.
- (5) When designing your equipment, comply with the range of absolute maximum rating and the guaranteed operating conditions (operating power supply voltage and operating environment etc.). Especially, please be careful not to exceed the range of absolute maximum rating on the transient state, such as power-on, power-off and mode-switching. Otherwise, we will not be liable for any defect which may arise later in your equipment.
 - Even when the products are used within the guaranteed values, take into the consideration of incidence of break down and failure mode, possible to occur to semiconductor products. Measures on the systems such as redundant design, arresting the spread of fire or preventing glitch are recommended in order to prevent physical injury, fire, social damages, for example, by using the products.
- (6) Comply with the instructions for use in order to prevent breakdown and characteristics change due to external factors (ESD, EOS, thermal stress and mechanical stress) at the time of handling, mounting or at customer's process. When using products for which damp-proof packing is required, satisfy the conditions, such as shelf life and the elapsed time since first opening the packages.
- (7) This book may be not reprinted or reproduced whether wholly or partially, without the prior written permission of Matsushita Electric Industrial Co., Ltd.